

POSITIONERS

	Positioner model	Controller	Controlled axes	Max. load capacity (kg)	Weight (kg)	Motion range [°]		Maximum speed [°/sec]		J1 Moment (Rotation/Bending) [Nm]/ Inertia [kgm ²]	J2 Moment [Nm]/ Inertia [kgm ²]
						J1	J2	J1	J2		
Positioner	1-Axis, 300 kg payload (hollow type)	R-30iA	1	300	85	740	—	160	—	353/2450/260	—
	1-Axis, 500 kg payload (hollow type)		1	500	88	740	—	130	—	588/3920/360	—
	1-Axis, 1000 kg payload (hollow type)		1	1000	280	740	—	120	—	1568/20580/461	—
	1-Axis, 1500 kg payload (hollow type)		1	1500	280	740	—	90	—	1960/20580/686	—
	1-Axis, 1000 kg payload (compact type)		1	1000	130	740	—	120	—	1568/7056/461	—
	1-Axis, 1500 kg payload (compact type)		1	1500	130	740	—	90	—	1960/7056/686	—
	2-Axes, 500 kg payload		2	500	295	270	480	120	190	1764/ — /300	686/100



FANUC Robotics offers the following standard positioners that can be used for a range of applications requiring coordinated motion:

- 1-axis and 300 kg / 500 kg payload
- 1-axis and 1000 kg / 1500 kg payload
- 1-axis follower unit with up to 1500 kg payload
- 2-axes and 500 kg payload

THE **POSITIONER** SERIES ARE IDEAL COMPANIONS FOR FANUC ROBOTS IN EVERY APPLICATION WHERE PRECISE POSITIONING OF PARTS IS NECESSARY.

» FEATURES AND BENEFITS

Positioners can be used in:

- Arc welding
- Sealing, glueing
- Spot welding
- Dispensing
- Coating
- Polishing, deburring

FAST INSTALLATION

- All necessary software and hardware are prepared by FANUC. This 100% FANUC solution allows fast and easy plug and play setup.

HEAVY PAYLOAD

- With 300kg to 1500kg payload, the FANUC positioners can move large work pieces quickly and precisely.

PERFECT COORDINATION WITH FANUC ROBOTS

- The positioners can be supplied with all FANUC robots.
- Their high speed and high acceleration guarantee a highly coordinated motion between positioner and robot. This is essential to achieve a high product quality and throughput.



1-axis servo positioner (300kg/500kg, hollow type)

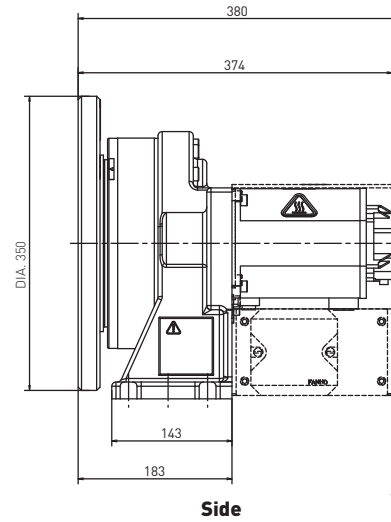
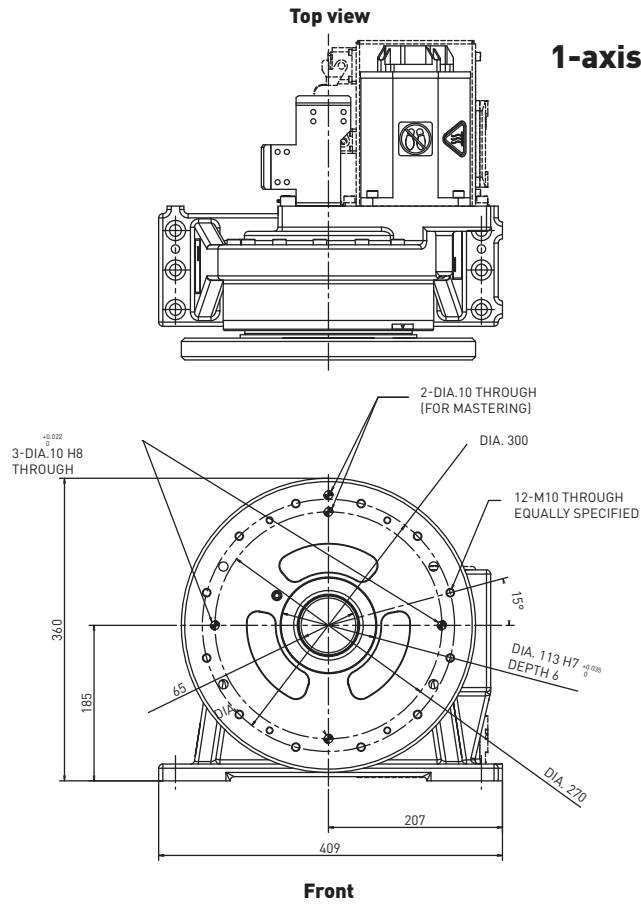

1-axis servo positioner (1000kg, 1500kg, hollow type)

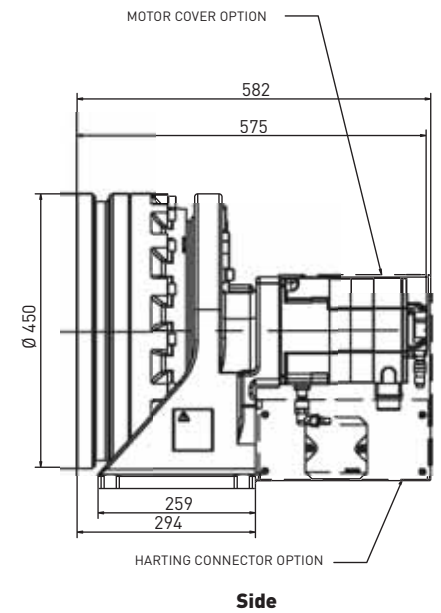
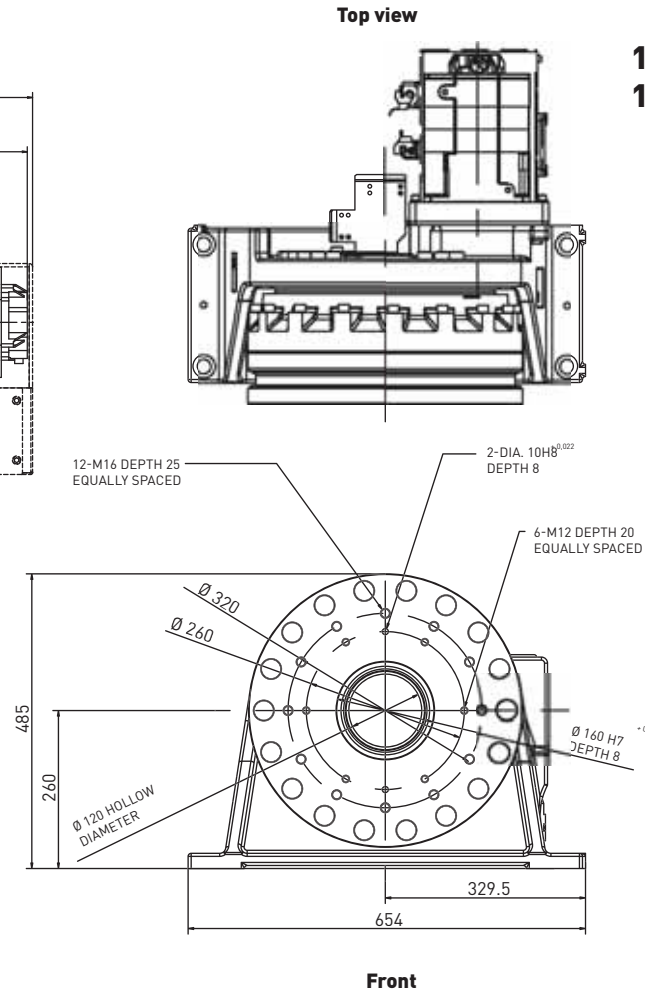

Dimensions

2-axes servo positioner

